

UNION SPECIAL CORPORATION

Catalog No. T104 RA
(Supplement to Catalog No. 104 R)

STYLES OF MACHINES

Streamlined Flat Bed, Four Needles, Left Needle in Front for Each Pair of Needles, Independent Row, High Throw, Close-Coupled Puller With Clutch in Upper Feed Roller, Compensating Lower Feed Roller, Single Disc Take-up, Light Weight Presser Bar and Needle Bar Driving Mechanism, Single Reservoir Enclosed Automatic Lubricating System, Filter Type Oil Return Pump and Oil Siphon Assembly, Lateral Looper Travel, Maximum Work Space to Right of Needle Bar 7 3/4 Inches.

51800 CA For attaching bibs to overalls and for similar operations on medium heavy to heavy weight sanforized and non-sanforized materials. Strips used in long lengths guided next to feed dog. Floor treadle controlled strip collapsing mechanism. Knee press for raising presser foot. Seam specification 401-LS1-4. Type 130 GS needle. Standard gauges Nos. 12-56-12, 12-64-12, 16-64-16, 16-76-16. Maximum recommended speed 4800 R.P.M.

51800 CB Same as 51800 CA, except it is not equipped with strip collapsing mechanism and has a floor treadle for raising the presser foot. Maximum recommended speed 4800 R.P.M.

APPLICATION OF CATALOG

This catalog is a supplement to Catalog No. 104 R and should be used in conjunction therewith. Only the parts found on Styles 51800 CA and CB, but not on Styles 51800 BA and BB are illustrated. On the back is an illustration identifying the parts by reference number and on the opposite page, the part numbers and descriptions identifies the part. Any part that is a component of another part is indicated by indenting its description under the description of the assembly or base part. Always use the part number in the second column, never use the reference number in the first column when ordering repair parts.

IDENTIFYING PARTS

Where the construction permits, each part is stamped with its part number. On some of the smaller parts, and on those where the construction does not permit, an identification letter is stamped in to distinguish the part from similar ones.

Part numbers represent the same part, regardless of the catalog in which they appear.

IMPORTANT! ON ALL ORDERS, PLEASE INCLUDE PART NUMBER AND STYLE OF MACHINE FOR WHICH PART IS ORDERED.

TERMS

Prices are strictly net cash and are subject to change without notice. All shipments are forwarded f.o.b. shipping point. Parcel Post shipments are insured unless otherwise directed. A charge is made to cover the postage and insurance.

NEEDLES

Needle Type 130 GS is recommended for Style 51800 CA and CB. The description and sizes available are as follows:

130 GS Round shank, round point, short, double groove, struck groove, ball eye, spotted, government, chromium plated - sizes 080/032, 090/036, 100/040, 110/044, 125/049, 140/054, 150/060.

To have needle orders promptly and accurately filled, an empty package, a sample needle, or the type and size number should be forwarded. Use description on label. A complete order would read: "1000 needles, Type 130 GS, Size 140/054".

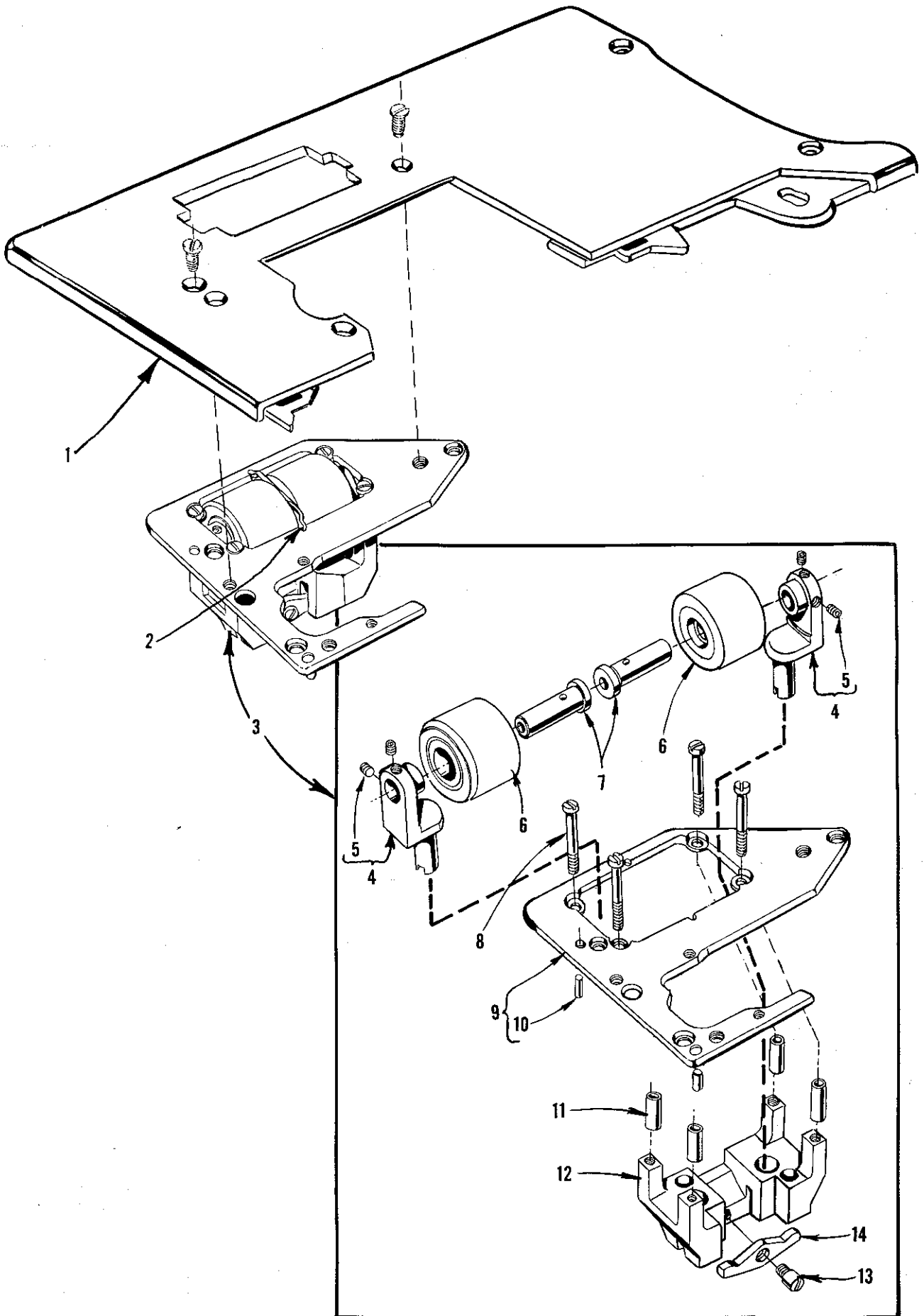

The parts illustrated on the preceding page and described below, represent the parts that are used on Styles 51800 CA and CB, but not used on Styles 51800 BA and BB.

Use Catalog No. 104 R (Styles 51800 BA and BB) for all parts not illustrated or described in this catalog.

Reference numbers that are inside a bracket or box on the picture plate and have indented descriptions, indicate they are component parts of a complete part or assembly.

| <u>Ref. No.</u> | <u>Part No.</u> | <u>Description</u> | <u>Amt. Req.</u> |
|-----------------|-----------------|--|------------------|
| 1 | 51801 C | Cloth Plate ----- | 1 |
| 2 | 51876 F | Lower Roller Stripper Wire ----- | 1 |
| 3 | 29476 MF | Throat Plate Support and Lower Roller Assembly ----- | 1 |
| 4 | 51876 A | Roller Shank ----- | 2 |
| 5 | 22894 W | Set Screw ----- | 2 |
| 6 | 51876 | Lower Feed Roller, rubber ----- | 2 |
| 7 | 51876 B | Roller Stud ----- | 2 |
| 8 | 22592 A | Screw, for roller shank housing ----- | 4 |
| 9 | 51880 A | Throat Plate Support ----- | 1 |
| 10 | 51280 J | Dowel Pin ----- | 2 |
| 11 | 51876 E | Spacer Bushing ----- | 4 |
| 12 | 59276 A | Roller Shank Housing ----- | 1 |
| 13 | 22845 M | Screw Stud ----- | 1 |
| 14 | 51876 D | Roller Shank Rocker ----- | 1 |
| - | 51281 AG-95 | Cloth Plate Cover, for No. 16-76-16 gauge machines only (not shown) ----- | 1 |



Union Special
INDUSTRIAL SEWING MACHINES

UNION SPECIAL maintains sales and service facilities throughout the world. These offices will aid you in the selection of the right sewing equipment for your particular operation. Union Special representatives and service men are factory trained and are able to serve your needs promptly and efficiently. Whatever your location, there is a Union Special Representative to serve you. Check with him today.

ATLANTA, GA.

BOSTON, MASS.

CHICAGO, ILL.

DALLAS, TEXAS

LOS ANGELES, CAL.

NEW YORK, N. Y.

PHILADELPHIA, PA.

MONTREAL, CANADA

TORONTO, CANADA

BRUSSELS, BELGIUM

LEICESTER, ENGLAND

LONDON, ENGLAND

PARIS, FRANCE

STUTT GART, GERMANY

Representatives and distributors in all important industrial cities throughout the world.

UNION SPECIAL CORPORATION
400 N. FRANKLIN ST., CHICAGO, ILL. 60610